

## DATA SHEET

# IDEAL 8000

U<sub>w</sub>-Value  
≥ 0.80

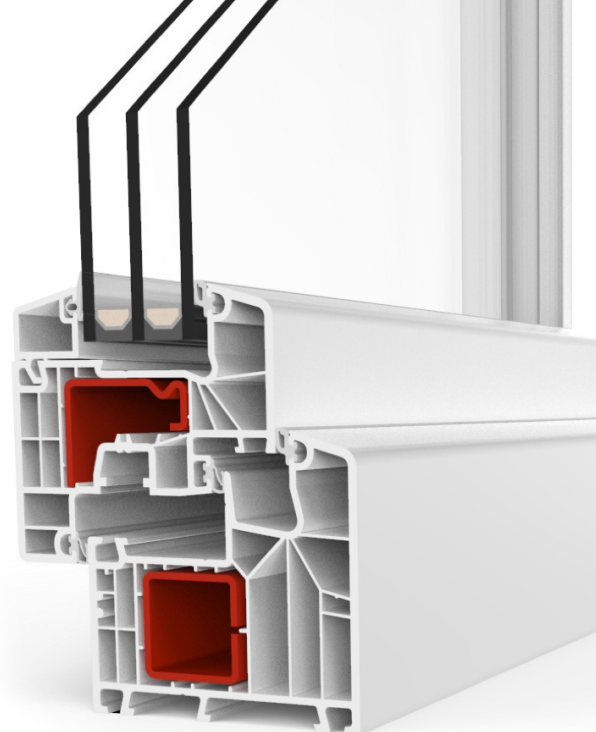

- Offset design
- 85 mm construction depth
- 6-chamber profile with 3 seals

### Energy saving through new windows

U <sub>w</sub> value (old)	3.50 W/(m <sup>2</sup> K)
U <sub>w</sub> value (new)	0.80 W/(m <sup>2</sup> K)
Window area	30 m <sup>2</sup>
Annual fuel oil savings	1082 litres
Annual carbon dioxide reduction	2,922 kg

### Explanation

Heating degree days	4,050
Conversion factor kilogram into litres of heating oil	1.19
Conversion of calorific value Wh/kg	11,800
Heating efficiency	0.75

### SAFETY EQUIPMENT / FITTING

#### BASIS:

- Fitting with 3 locking plates
- 3-dimensionally adjustable
- Anti mishandling device
- Sash lifter
- Max. sash weight 130 kg

#### OPTIONAL:

- ActivPilot Comfort PAD (parallel stop fitting)
- Safety levels: RC1, RC2, according to EN 1627-1630
- SELECT fitting (concealed corner and shear bearings)
- "Tilt before Turn"
- High Control (magnetic contact for electronic monitoring)

### COLOURS

- White
- Decor according to current price list according to colour range uPVC

### SOUND INSULATION

Window RwP up to 44 dB

### GLASS THICKNESS

To 51 mm

### SEALS

- Centre sealing system
- 3 sealing levels
- Possible colours:
  - Papyrus white or black for decor



## SYSTEM VALUES

- Air permeability: Class 3 (according to EN 12207)
- Driving rain-proof: Class 4A (according to EN 12208)
- Water tightness against driving rain: Class B3 (according to EN 12210)

### Please note:

The classes given here are minimum classes. For higher requirements please consult us.

## THERMAL INSULATION

- Reference size 1230 x 1480 mm
- $U_f = 1.0 \text{ W/(m}^2\text{K)}$
- Minimum requirement according to GEG2020  $U_w = 1.3 \text{ W/(m}^2\text{K)}$
- PHT = suitable for passive houses

$U_g$ Glass ( $\text{W/m}^2\text{K}$ ) according to EN 673	$U_w$ window ( $\text{W/m}^2\text{K}$ )		
	Type of edge spacer		
	Aluminium	KSH / KSD	Swisspacer Ultimate
<b>Double glazing</b>	$\text{Psi} = 0.066$ ( $\text{W/mK}$ )	$\text{Psi} = 0.041$ ( $\text{W/mK}$ )	$\text{Psi} = 0.032$ ( $\text{W/mK}$ )
1.1	1.23	1.17	1.15
1.0	1.16	1.10	1.08
<b>Triple glazing</b>	$\text{Psi} = 0.064$ ( $\text{W/mK}$ )	$\text{Psi} = 0.039$ ( $\text{W/mK}$ )	$\text{Psi} = 0.030$ ( $\text{W/mK}$ )
0.8	1.02	0.96	0.94
0.7	0.95	0.89	0.87
0.6	0.89	0.82	0.80
0.5	0.82	0.76 (PHT)	0.74 (PHT)

$U_w$  values  $< 1.0 \text{ W/(m}^2\text{K)}$  are shown with two decimal places in accordance with EN ISO 10077

$U_w$  values  $> 1.0 \text{ W/(m}^2\text{K)}$  are shown with one decimal place according to EN ISO 10077, here with two decimal places for information purposes

The PSI values given are taken from the data sheets of the "Warm Edge" working group

## SOUND INSULATION

Reference size 1230 x 1480 mm  
(Elements with test certificate)

$R_w \triangleq R_{wp}$ = test value window	$R_{wr}$ = calculated value window	$R_{wp}$ = test value glass	Test certificate no.
34 dB	32 dB	32 dB	11-000823-PR01
38 dB	36 dB	36 dB	11-000823-PR01
39 dB	37 dB	38 dB	11-000823-PR01
42 dB	40 dB	41 dB	11-000823-PR01
44 dB	42 dB	45 dB	11-000823-PR01
46 dB	44 dB	48 dB	11-000823-PR01

For Germany, the following applies according to DIN 4109:1989-11:  
 $R_w$  corresponds to  $R_{wp}$ ;  $R_{wr} = R_{wp} - 2\text{dB}$

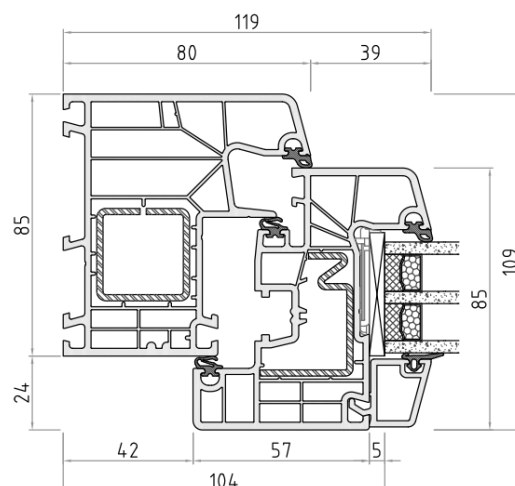

IDEAL 8000 FRAME WITH SASH

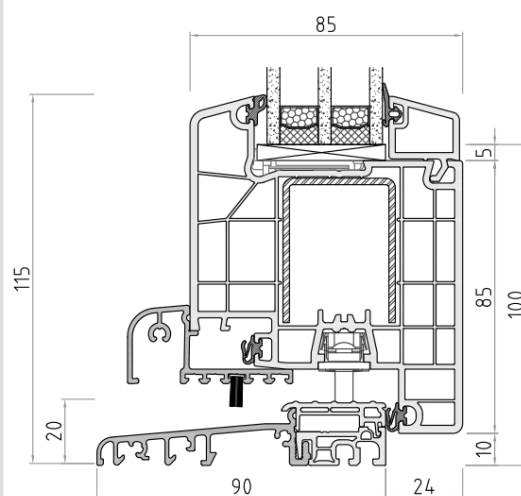

IDEAL 8000  
FRENCH DOORS WITH FLAT THRESHOLD

## POSSIBLE GLASS STRIPS:

STANDARD

